



# USER CARE AND OPERATIONS GUIDE



WINDOWS, DOORS & CONSERVATORIES OF DISTINCTION

# WINDOWS

**Thank you for choosing from our portfolio of windows, doors and conservatories. We are sure you will benefit from the quality of manufacture and installation of our products.**

**Please take the time to read this document containing important information on how to get the best from your investment now, and for many years to come.**

## CASEMENT OUTWARD OPENING WINDOWS

### OPERATION

All windows are provided with key-locking handles. The handles will automatically engage when the handle is in the closed position. To open the window, simply press the button before attempting to turn the handle. For added security, the handle will not move when locked by using the key.

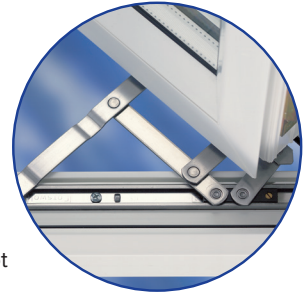

The window can be locked in a ventilation position allowing a gap for fresh air to pass between sash and frame. It must be stated, however, that in this position, the window cannot be regarded as secure.

### ADJUSTMENT

It is possible over time, for the hinge (friction stay) to become slack or over tight. This can be rectified by gently adjusting the screw indicated to increase or reduce friction (see diagram above).

### EGRESS OPERATION

For windows fitted with Defender friction hinges and easy clean option, the following instructions must be followed when cleaning the outside of the window:-



- 1) Open the window fully and find the levers on the top and bottom window hinges.
- 2) Press one lever and slide the window slightly towards the centre of the opening. Repeat for the second lever.
- 3) Using both hands, slide the window evenly to gain access to clean the outside of the window.
- 4) To reset the hinges to their normal operating mode, simply close the window.

## TILT AND TURN WINDOWS

When the window is closed the handle should be in the vertical position with the pointed end down. To place the window in the tilt position, turn the handle through 90 degrees and then pull gently towards you. The window will come to rest in the tilt position.

If it is required to fully open the window for cleaning or emergency access, ensure that the window is firmly in place against the frame, before turning the handle to the open position, with the pointed end now upwards. The window can now be fully opened inwards.

To close and lock, simply push the window until it is firmly in place against the frame and then rotate the handle fully 180 degrees until the handle is in the vertical position, with the pointed end down. For added security, movement of the handle can be locked by using the key.

### MAINTENANCE

To ensure smooth operation of the Winkhaus Active Pilot fitting, all moving components and all locking points on the tilt-turn fittings should be **greased once a year**. By doing so you protect the fittings from premature wear and tear.



## VERTICAL SLIDING WINDOWS

### OPENING SASHES

#### To slide lower sash up:

Unlock Fitch Catch (located on top of lower sash) with key and then fully rotate lever to the right. Using the finger pulls, located on the bottom rail of lower sash, slide up to required position.

#### To slide upper sash down:

Firstly slide the lower sash up (as above). Using the D Handles, located outside on the bottom rail of upper sash, slide down to required position. You may now close the bottom sash if required.

**Please note:** If window is fitted with Limit Stops the sashes will only slide to a predetermined point. To allow the sash to fully open, the Limit Stops have to be unscrewed anti-clockwise using the key provided (Rola type) or pressed home and locked back by turning the key (Sharks Fin type).

### CLEANING OUTSIDE OF WINDOW

Slide lower sash up by approximately 50mm (2 inches). Slide the 2 buttons which are located on the top of the lower sash towards each other, and gently pull top of sash into the room. The sash will stop tilting at approximately 200mm as in built restrictors are fitted. Now slide the upper sash down by 50mm. Slide the 2 buttons which are located on the top of the upper sash towards each other and gently pull top of sash into the room. The sash will stop tilting at approximately 200mm. The outside of the window can now be cleaned.

## FULLY REVERSIBLE WINDOWS

1. Ventilation - Open the window to first restricted position.
2. Opening Window - To open window to second restricted position, press button A whilst pushing window open.
3. Cleaning - Press button A and push window open to arms length, then continue reversal by pulling window from the top until window engages with restrictor.
4. Closing Window - Reverse the previous actions, pushing button A at each stage.

**IMPORTANT: DO NOT CLOSE THE WINDOW WITHOUT FIRST PRESSING BUTTON A**

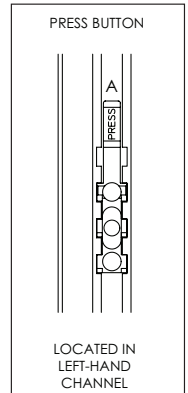

### MAINTENANCE

The main areas for lubrication are shown for both the left hand gearing (restricted hinge) as well as the right hand gearing (unrestricted hinge).

The hinges are handed from the inside of the building looking out.

(1) The toplider track must be kept clean and free from any obstructions. If any fixings have been used in this track care must be taken to ensure smooth reversal without interference with nylon gliders. The toplider track should be kept lightly lubricated with acid free oil, vaseline. The toplider track must not be repainted. Lubrication when necessary, min once a year.

(2) The aluminium track behind the restrictor arm should be lubricated as (1). The fixing screws should be secured making sure they do not interfere with the smooth movement of the gearing. Lubrication when necessary, min once a year.

**NB:**(3) The steel bar on the left hand restricted arm should be lubricated during fabrication as (1). Lubrication when necessary, min once a year.

(3a) Wheel on right hand unrestricted hinge should be lubricated as (1). Lubrication when necessary, min once a year.

(4, 5, 7, 8) Rivets to be lubricated as (1). Lubrication when necessary, min once a year.

(6) Pivot point is pre lubricated from production. Check it is still intact, if not then lubricate. Lubrication when necessary, min once a year.

**NOTE:** Frequency of lubrication must be increased in corrosive areas

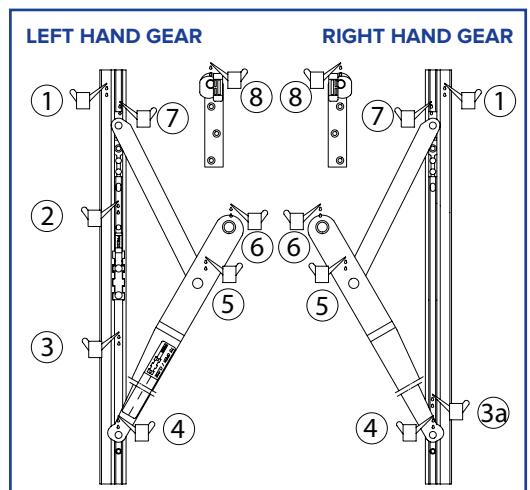

# DOORS

## ENTRANCE DOORS

The door is normally operated by pressing the handle down from the horizontal position until the latch is released and the door will open. To close, simply press the opening sash until it meets the frame and the audible click of the latch is heard to operate. For added security, and for full compression to eliminate drafts and warping, lift the handle to engage the additional locking points and compression cams.



To deadlock the door it is necessary to raise the handle as far as it will go **before turning the key**. This action will engage the lock-bolts and the key will engage the deadlock to the door securely. If the handle is not raised sufficiently, the lock will not engage.

To re-open the door, turn the key and then press the handle downwards until the door opens.

**An alternative to the above is to have a lock that can only be opened from the outside by using a key.**

In this case, the door operates from the inside in exactly the same way as above. However, from the outside, the handle will not release the catch but is used to engage the lockbolts in the same manner as above. To re-open the door, turn the key and then press the handle downwards as far as it will go. Turn the key once more to release the latch and the door will open.

## FRENCH DOORS

The first door that opens is called the Master door and the second door is called the Slave door. The Master door is operated in the same fashion as described in the first part of the entrance door section.

The Slave door could have one of two types of locking method. On type 1 there will be a handle only on the Master door.

### TYPE 1 (FINGER BOLTS)

Once the Master door is open, simply release the Slave door by turning the finger bolts (located at the top and bottom of the door) towards the centre of the door.

### TYPE 2 (PASSIVE LOCK)

This type has a handle on both doors. Once the Master door is open, turn the key on the Slave door, then push the handle downwards to release the top and bottom shoot-bolts. To re-lock, press the door sash against the frame, lift the handle as far as it will go, before turning the key to lock the Slave door.

## PANIC DOORS

### FACE FIT PANIC EXIT DEVICE

Weekly and monthly maintenance checks should be undertaken at regular intervals to ensure performance.



#### WEEKLY:

- 1) A visual inspection and operation of the device to ensure that all components are working correctly.
- 2) Ensure that the strikers are free from obstruction, latches move freely and pass by the striker when operated.
- 3) Check for any loose components - tighten if necessary.

#### MONTHLY:

- 1) Check operation of device with door open several times - then again with door closed.
- 2) Ensure that the strikers are free from obstruction and latches are fully extended when in the closed position.
- 3) Remove covers and check that all moving parts of the mechanisms and the latches are lubricated. Please note however that the Dr Hahn hinges on the doors must **NOT** be oiled at any time as damage may occur.
- 4) Check operation of device with covers removed for any obstructions.
- 5) Check tightness of all fixing screws and replace covers.
- 6) Check that no additional locking devices have been added to the door since its original installation.
- 7) Check that the operating element is correctly tightened and measure the operating forces to release the exit device. Check that the operating forces have not changed significantly from the operating forces when originally installed.

# PANIC DOORS

## CONCEALED PANIC EXIT DEVICE

### MULTI-SAFE 870 - SINGLE DOOR

Locking and unlocking is carried out with two key turns. It is opened from the inside by operating either the lever-handle or the push bar, and from the outside via the profile cylinder key. On the panic version D, the latch can also be retracted via the exterior lever-handle.

### MULTI-SAFE 870 - DOUBLE DOOR

Locking and unlocking the active leaf is carried out with two key turns. The passive leaf automatically locks top and bottom when the door is closed over. It is opened from the inside by operating either the lever-handle or the push bar - regardless of which door leaf is operated. The door is opened from the outside via the profile cylinder key. On the panic version D the latch can also be retracted via the exterior lever-handle. Following a panic opening operation via the passive leaf, the active leaf's locking components must be retracted with the key.

## MAINTENANCE OF PANIC DOORS

Safety relevant hardware components - depending on their frequency of use - are to be checked for wear and tear and if they are mechanically secured, at least once a month. At the same time the panic/emergency opening function should be checked. Depending on the requirements, fixing screws must be tightened or the damaged or worn parts exchanged for original parts by a specialised company.

Furthermore it is necessary that the following service work be carried out at least once a year.

- 1) All movable parts and locking points must be lubricated and their function must be checked. Please note however that the Dr Hahn hinges on the doors must **NOT** be oiled at any time as damage may occur.
- 2) The panic locking system's function via the actuating bar must be easy to operate throughout the entire operation cycle.
- 3) Only cleaning and maintenance agents, which do not damage the corrosion protection of the hardware components are to be used.
- 4) We recommend you consider a service and maintenance contract with an authorised specialist company.

## STABLE DOORS

The stable door has a dual locking system that enables the top half of the door to be unlocked and operated separately to the bottom half of the door and vice versa.



To open the door fully with both the top half and bottom half together, both parts of the door will need to be unlocked. When closing the door with both halves together, you must ensure the top lock and bottom lock has been actioned for secure locking.

## IN-LINE SLIDING PATIO DOORS

To open, turn the key to unlock, push the lever downwards, and then slide the door to one side. To close, reverse this sequence.

### MAINTENANCE FOR SLIDING DOORS

#### uPVC

Cleaning of uPVC profiles is extremely simple: the profiles just need to be washed with a soft damp sponge, which may be impregnated with a non-abrasive household cleaner (do NOT use any cleaner containing ammonia or chlorine such as bleach). Also NOT permitted is the use of abrasive, corrosive liquids and chemical solvents such as benzene, acetone, turpentine, kerosene, white spirit and similar.

Foiled profile can be easily cleaned with a household water based cleaner with the aid of a soft sponge (do NOT use any cleaner containing ammonia or chlorine such as bleach). It is NOT recommended to use any aggressive products such as for example methylene chloride, hydrogen peroxide, cellulose thinner, acetone etc. Foiled windows should also NOT be cleaned with a steam cleaner.

#### Seals

The material used for the seals is TPE (thermoplastic elastomer). It is normal that some discolouration of the mastic may occur, but this will not affect performance. It is NOT recommended that you use concentrated detergents or similar products on these seals.

#### Hardware

uPVC doors are always provided with durable fittings. For a proper operation and a long life, all the moving parts need to be checked at least once a year and where necessary, lubricated.



# MAINTENANCE



## LUBRICATION

There is no such thing as a maintenance-free product. All moving parts require preventative maintenance to prolong operational life and to maintain the product guarantee. All handles, hinges, locks and friction stays should be kept clean and occasionally lubricated.

**Door Locks and Cylinders** - A PTFE or graphite based lubricant.

**Friction Hinges** - Vaseline or similar light grease.

**Window and Door Handles and Window Locks** - WD40, 3-in-1 or similar.

**Please note however that the Dr Hahn hinges on panic doors must NOT be oiled at any time as damage may occur.**

## MASTIC SEALS

A high-performance mastic is used to seal between the PVCu products and the walls to prevent the possible ingress of draughts and water. It is normal that some discolouration of the mastic may occur, but this will not affect performance.

## CLEANING

**Windows & doors:** On a regular basis all PVCu surfaces should be washed down with warm soapy water - the more the better! Abrasive cleaners should NOT be used as these will remove the natural skin of the PVCu and render it less resistant to the atmosphere. For stubborn stains GENTLY use a good quality car polish. Similarly, do not use abrasive materials on painted, anodized or lacquered components.

All windows and doors are provided with drainage holes. These must be kept clear otherwise the performance of the product will be affected.

If you have windows with decorative leading, external astragal Georgian bar, care should be taken whilst cleaning to prevent possible dislodging. All weathering gaskets and seals should be kept clean. If these are dislodged they can easily be pushed back into position, but if they become damaged they will have to be replaced to maintain product performance.

**Hardware:** All hardware surfaces (handles, letter plates and door knockers etc.) must be regularly cleaned with a soft damp cloth, whilst taking care not to scratch the surface. **By not caring for these particular products may invalidate your product guarantee.** Please note: components supplied by us are guaranteed on the understanding that they are not installed within a marine environment, within 3 miles of the sea, unless they have been specified as corrosion resistance.

**Conservatories:** Conservatory roofs should be regularly washed down with soapy water. Try to avoid it but, if you need to climb onto the roof, extreme care should be taken to avoid direct contact with the roof. Place scaffold boards to span between load bearing elements of the structure (rafters), to spread the load. Avoid leaning ladders against gutters, PVCu frames or roof sheets.

Gutters and down pipe outlets must be kept clear of debris. It is normal for a small amount of standing water to be found in the gutter.

# MAINTENANCE



## RESIDENCE COLLECTION - Flush Windows & Doors

The below covers The Residence Collection recommendations for maintaining your windows and doors. If all guidance is followed correctly, your windows and doors should maintain their premium finish and operate smoothly.

## CLEANING

Please remove any jewellery from your hands or wrists before cleaning your windows and doors to prevent any scratches.

## CARING FOR YOUR RESIDENCE WINDOWS & DOORS

**Cleaning sash, frame and cills:** We recommend using warm soapy water (your usual soap detergent should do) with a soft cloth, nothing harsh or abrasive, on the frames and cills. Simply wipe with the warm water and dry with a clean, dry, soft cloth.

**'Easy Clean' rebates:** Intelligently designed with an 'Easy-Clean' frame rebate. Open your windows or doors and simply wipe clean.

**Glass Cleaning:** For the best finish use a household window cleaner and soft cloth. Make sure the cloth is free of stones or debris to prevent scratching the glass. The best way to keep it streak free is to use a squeegee, it is fast and leaves glass super clear! Wash from top to bottom to avoid drips. Bonus tip - wash windows on a cloudy day! The sun can prematurely dry windows adding streaks.

**Hardware:** To ensure optimum performance, hinges, locking mechanisms and handles will require periodic lubrication. One drop of a light machine oil (eg WD40/3-in-1 oil) is plenty, wipe away any excess. Be careful to not get any oil on the main profile.

Wipe clean tracks for hinges to keep them dirt free and moving freely.

**Easy Clean Hinge Operation (if applicable):** To activate 'Easy Clean' mode push both black slide buttons of the hinges (top and bottom) towards the corner and slide the sash away from the edge.

# GLASS



Because the production of glass is an exceptionally aggressive process, slight imperfections cannot be avoided and are accepted as an industry standard which states:-

1. Transparent glass used in the manufacture of double-glazed units is identical to that used in traditional single glazing and therefore will have a similar level of quality.
2. Both panes of the double-glazed units shall be viewed from the room side, standing at a distance of two metres (6.5 feet) in natural daylight and not in direct sunlight. The area to be viewed is the normal vision area with the exception of a 50mm (2 inch) band around the perimeter of the unit.
3. Transparent glass shall be deemed acceptable if the following phenomena are neither obtuse or bunched:-
  - a) totally enclosed seeds
  - b) bubbles or blisters
  - c) hairline or blobs
  - d) fine scratches not more than 25mm (1 inch) long
  - e) minute embedded particles
4. Obtrusiveness of blemishes shall be judged by looking through the glass and not at it, under normal lighting conditions as described as above.

## **Extracted from the standards of the Glass and Glazing Federation.**

*Patterned glass is manufactured in very large sheets and due to the nature of production the centralisation and matching of design in an individual unit cannot be guaranteed. It should also be pointed out that there is not a correct 'right way up' of pattern.*

## **CONDENSATION**

Washing, cooking, bathing, even the act of breathing will produce water vapour. However, it will only normally show when in contact with a cool surface. Condensation can never be eliminated and can only be reduced by ventilation to allow the water vapour to escape. Leave windows open in the trickle ventilation position as required, bearing in mind that security may be compromised if the house is left unattended with windows in the ventilation position.

## **PRODUCT GUARANTEE**

**Please be aware that not maintaining and caring for your products as advised in this document could invalidate your product guarantee.**

**Apart from the ongoing care and maintenance guidelines contained in this document, only authorised personnel should carry out any remedial work or adjustments to any of the products installed. Please contact us for advice and assistance - especially if the item is covered by warranty.**



**For further assistance, call 01702 613733**

**[www.climatec-windows.co.uk](http://www.climatec-windows.co.uk)**

11-14 Fletchers Square, Temple Farm Industrial Estate, Southend-on-Sea, Essex SS2 5RN